

OUTDOOR UNITS

1. SPECIFICATIONS	2 - 134
2. EXTERNAL DIMENSIONS	2 - 137
3. CENTER OF GRAVITY	2 - 140
4. ELECTRICAL WIRING DIAGRAMS	2 - 141
5. SOUND LEVELS	2 - 142
6. CAPACITY TABLES	2 - 143
6-1. Correction by temperature	2 - 143
6-2. Correction by total indoor	2 - 144
6-3. Correction by refrigerant piping length	2 - 146
6-4. Correction at frost and defrost	2 - 147
6-5. Operation temperature range	2 - 147
7. OPTIONAL PARTS	2 - 148
7-1. JOINT	2 - 148
7-2. HEADER	2 - 149
7-3. OUTDOOR TWINNING KIT	2 - 150

1. SPECIFICATIONS

DATA G6

Model		PUHY-HP200YHM-A(-BS)		PUHY-HP250YHM-A(-BS)	
Power source		3-phase 4-wire 380-400-415V 50/60Hz		3-phase 4-wire 380-400-415V 50/60Hz	
Cooling capacity (Nominal)	*1	kW	22.4	28.0	
	*1	kcal / h	19,300	24,100	
	*1	BTU / h	76,400	95,500	
	Power input	kW	6.40	9.06	
	Current input	A	10.8-10.2-9.8	15.2-14.5-14.0	
	COP	kW / kW	3.50	3.09	
Temp. range of cooling	Indoor	W.B.	15 to 24degC(59 to 75degF)		15 to 24degC(59 to 75degF)
	Outdoor	D.B.	-5 to 43degC(23 to 109degF)		-5 to 43degC(23 to 109degF)
Heating capacity (Nominal)	*2	kW	25.0	31.5	
	*2	kcal / h	21,500	27,100	
	*2	BTU / h	85,300	107,500	
	Power input	kW	6.52	8.94	
	Current input	A	11.0-10.4-10.0	15.0-14.3-13.8	
	COP	kW / kW	3.83	3.52	
Temp. range of heating	Indoor	D.B.	15 to 27degC(59 to 81degF)		15 to 27degC(59 to 81degF)
	Outdoor	W.B.	-25 to 15.5degC(-13 to 60degF)		-25 to 15.5degC(-13 to 60degF)
Indoor unit connectable	Total capacity		50 to 130 % of outdoor unit capacity		50 to 130 % of outdoor unit capacity
	Model / Quantity		P15 to P250 / 1 to 17		P15 to P250 / 1 to 21
Sound pressure level (measured in anechoic room)		dB <A>	56	57	
Refrigerant piping diameter	Liquid pipe	mm(in.)	12.7(1/2) Brazed	12.7(1/2) Brazed	
	Gas pipe	mm(in.)	19.05(3/4) Brazed	22.2(7/8) Brazed	
FAN	Type x Quantity		Propeller fan x 1		Propeller fan x 1
	Air flow rate	m ³ / min	225	225	
		L/s	3,750	3,750	
		cfm	7,945	7,945	
	Control, Driving mechanism		Inverter-control, Direct-driven by motor		Inverter-control, Direct-driven by motor
	Motor output	kW	0.92 x 1	0.92 x 1	
*3	External static press.		0 Pa (0 mmH ₂ O)	0 Pa (0 mmH ₂ O)	
Compressor	Type x Quantity		Inverter scroll hermetic compressor		Inverter scroll hermetic compressor
	Manufacture		AC&R Works, MITSUBISHI ELECTRIC CORPORATION		AC&R Works, MITSUBISHI ELECTRIC CORPORATION
	Starting method		Inverter		Inverter
	Motor output	kW	5.3	6.7	
	Case heater	kW	0.045	0.045	
Lubricant			MEL32	MEL32	
External finish			Pre-coated galvanized steel sheets <MUNSELL 5Y 8/1 or similar>	Pre-coated galvanized steel sheets <MUNSELL 5Y 8/1 or similar>	
External dimension HxWxD	mm		1,650 x 920 x 760	1,650 x 920 x 760	
	in.		65 x 36-1/4 x 29-15/16	65 x 36-1/4 x 29-15/16	
Protection devices	High pressure protection		High pressure sensor, High pressure switch at 4.15MPa (601 psi)		High pressure sensor, High pressure switch at 4.15MPa (601 psi)
	Inverter circuit (COMP. / FAN)		Over-heat protection, Over-current protection		Over-heat protection, Over-current protection
	Compressor		Over-heat protection		Over-heat protection
	Fan motor		Thermal switch		Thermal switch
Refrigerant	Type x original charge		R410A x 9.0kg (20lbs)		R410A x 9.0kg (20lbs)
	Control		LEV and HIC circuit		LEV and HIC circuit
Net weight	kg(lbs)	220(486)	220(486)		
Heat exchanger			Salt-resistant cross fin & copper tube		Salt-resistant cross fin & copper tube
HIC circuit (HIC: Heat Inter-Changer)			Copper pipe, tube-in-tube structure		Copper pipe, tube-in-tube structure
Defrosting method			Auto-defrost mode (Reversed refrigerant circle)		Auto-defrost mode (Reversed refrigerant circle)
Drawing	External		WKB94R110		WKB94R110
	Wiring		WKE79B230		WKE79B230
Standard attachment	Document		Installation Manual		Installation Manual
	Accessory		Refrigerant conn. pipe		Refrigerant conn. pipe
Optional parts			Joint: CMY-Y102S-G2 Header: CMY-Y104/108/1010-G		Joint: CMY-Y102S-G2 Header: CMY-Y104/108/1010-G
Remark			* Details on foundation work, duct work, insulation work, electrical wiring, power source switch, and other items shall be referred to the Installation Manual. * Due to continuing improvement, above specifications may be subject to change without notice.		* Details on foundation work, duct work, insulation work, electrical wiring, power source switch, and other items shall be referred to the Installation Manual. * Due to continuing improvement, above specifications may be subject to change without notice.

Note :	*1 Nominal cooling conditions (subject to JIS B8615-1)		*2 Nominal heating conditions (subject to JIS B8615-1)		Unit converter kcal =kW x 860 BTU/h =kW x 3,412 cfm =m ³ /min x 35.31 lbs =kg / 0.4536 *The specification data is subject to rounding variation.
	Indoor :	27degCDB/19degCWB (81degFDB/66degFWB)	20degCDB (68degFDB)		
	Outdoor :	35degCDB (95degFDB)	7degCDB/6degCWB (45degFDB/43degFWB)		
	Pipe length :	7.5m(24-9/16ft.)	7.5m(24-9/16ft.)		
	Level difference :	0m(0ft.)	0m(0ft.)		
*3 External static pressure option is available (30Pa, 60Pa / 3.1mmH ₂ O, 6.1mmH ₂ O).					

Model			PUHY-HP400YSHM-A(-BS)		
Power source			3-phase 4-wire 380-400-415V 50/60Hz		
Cooling capacity (Nominal)	*1	kW	45.0		
	*1	kcal / h	38,700		
	*1	BTU / h	153,500		
	Power input		kW	12.86	
	Current input		A	21.7-20.6-19.8	
COP		kW / kW	3.49		
Temp. range of cooling	Indoor	W.B.	15 to 24degC(59 to 75degF)		
	Outdoor	D.B.	-5 to 43degC(23 to 109degF)		
Heating capacity (Nominal)	*2	kW	50.0		
	*2	kcal / h	43,000		
	*2	BTU / h	170,600		
	Power input		kW	13.35	
	Current input		A	22.5-21.4-20.6	
COP		kW / kW	3.74		
Temp. range of heating	Indoor	D.B.	15 to 27degC(59 to 81degF)		
	Outdoor	W.B.	-25 to 15.5degC(-13 to 60degF)		
Indoor unit connectable	Total capacity		50 to 130 % of outdoor unit capacity		
	Model / Quantity		P15 to P250 / 1 to 34		
Sound pressure level (measured in anechoic room)			dB <A>		
			59		
Refrigerant piping diameter	Liquid pipe	mm(in.)	15.88(5/8) Brazed		
	Gas pipe	mm(in.)	28.58(1-1/8) Brazed		

Set Model

Model			PUHY-HP200YHM-A(-BS)		PUHY-HP200YHM-A(-BS)	
FAN	Type x Quantity		Propeller fan x 1		Propeller fan x 1	
	Air flow rate	m ³ / min	225		225	
		L/s	3,750		3,750	
		cfm	7,945		7,945	
	Control, Driving mechanism		Inverter-control, Direct-driven by motor		Inverter-control, Direct-driven by motor	
	Motor output	kW	0.92 x 1		0.92 x 1	
*3	External static press.		0 Pa (0 mmH ₂ O)		0 Pa (0 mmH ₂ O)	
Compressor	Type x Quantity		Inverter scroll hermetic compressor		Inverter scroll hermetic compressor	
	Manufacture		AC&R Works, MITSUBISHI ELECTRIC CORPORATION		AC&R Works, MITSUBISHI ELECTRIC CORPORATION	
	Starting method		Inverter		Inverter	
	Motor output	kW	5.3		5.3	
	Case heater	kW	0.045		0.045	
	Lubricant		MEL32		MEL32	
External finish			Pre-coated galvanized steel sheets <MUNSELL 5Y 8/1 or similar>		Pre-coated galvanized steel sheets <MUNSELL 5Y 8/1 or similar>	
External dimension HxWxD		mm	1,650 x 920 x 760		1,650 x 920 x 760	
		in.	65 x 36-1/4 x 29-15/16		65 x 36-1/4 x 29-15/16	
Protection devices	High pressure protection		High pressure sensor, High pressure switch at 4.15MPa (601 psi)		High pressure sensor, High pressure switch at 4.15MPa (601 psi)	
	Inverter circuit (COMP. / FAN)		Over-heat protection, Over-current protection		Over-heat protection, Over-current protection	
	Compressor		Over-heat protection		Over-heat protection	
	Fan motor		Thermal switch		Thermal switch	
Refrigerant	Type x original charge		R410A x 9.0kg (20lbs)		R410A x 9.0kg (20lbs)	
	Control		LEV and HIC circuit			
Net weight		kg(lbs)	220(486)		220(486)	
Heat exchanger			Salt-resistant cross fin & copper tube		Salt-resistant cross fin & copper tube	
HIC circuit (HIC: Heat Inter-Changer)			Copper pipe, tube-in-tube structure		Copper pipe, tube-in-tube structure	
Pipe between unit and distributor	Liquid pipe	mm(in.)	9.52(3/8) Flare		9.52(3/8) Flare	
	Gas pipe	mm(in.)	19.05(3/4) Brazed		19.05(3/4) Brazed	
Defrosting method			Auto-defrost mode (Reversed refrigerant circle)			
Drawing	External		WKB94R111			
	Wiring		WKE79B230		WKE79B230	
Standard attachment	Document		Installation Manual			
	Accessory		Refrigerant conn. pipe			
Optional parts			Outdoor Twinning kit: CMY-Y100VBK2 Joint: CMY-Y102S/L-G2, CMY-Y202-G2 Header: CMY-Y104/108/1010-G			
Remark			* Details on foundation work, duct work, insulation work, electrical wiring, power source switch, and other items shall be referred to the Installation Manual. * Due to continuing improvement, above specifications may be subject to change without notice.			

Note :	*1 Nominal cooling conditions (subject to JIS B8615-1)	*2 Nominal heating conditions (subject to JIS B8615-1)	Unit converter
Indoor :	27degCDB/19degCWB (81degFDB/66degFWB)	20degCDB (68degFDB)	kcal =kW x 860
Outdoor :	35degCDB (95degFDB)	7degCDB/6degCWB (45degFDB/43degFWB)	BTU/h =kW x 3,412
Pipe length :	7.5m(24-9/16ft.)	7.5m(24-9/16ft.)	cfm =m ³ /min x 35.31
Level difference :	0m(0ft.)	0m(0ft.)	lbs =kg / 0.4536
			*The specification data is subject to rounding variation.

*3 External static pressure option is available (30Pa, 60Pa / 3.1mmH₂O, 6.1mmH₂O).

1. SPECIFICATIONS

Model			PUHY-HP500YSHM-A(-BS)	
Power source	3-phase 4-wire 380-400-415V 50/60Hz			
Cooling capacity (Nominal)	*1 kW	56.0		
	*1 kcal / h	48,200		
	*1 BTU / h	191,100		
	Power input kW	18.16		
	Current input A	30.6-29.1-28.0		
Temp. range of cooling	COP kW / kW	3.08		
	Indoor W.B.	15 to 24degC(59 to 75degF)		
Outdoor D.B.	-5 to 43degC(23 to 109degF)			
Heating capacity (Nominal)	*2 kW	63.0		
	*2 kcal / h	54,200		
	*2 BTU / h	215,000		
	Power input kW	18.04		
	Current input A	30.4-28.9-27.8		
Temp. range of heating	COP kW / kW	3.49		
	Indoor D.B.	15 to 27degC(59 to 81degF)		
Outdoor W.B.	-25 to 15.5degC(-13 to 60degF)			
Indoor unit connectable	Total capacity	50 to 130 % of outdoor unit capacity		
	Model / Quantity	P15 to P250 / 1 to 43		
Sound pressure level (measured in anechoic room)	dB <A> 60			
Refrigerant piping diameter	Liquid pipe mm(in.)	15.88(5/8) Brazed		
	Gas pipe mm(in.)	28.58(1-1/8) Brazed		

Set Model

Model			PUHY-HP250YHM-A(-BS)		PUHY-HP250YHM-A(-BS)	
FAN	Type x Quantity	Propeller fan x 1		Propeller fan x 1		
	Air flow rate	m ³ / min	225		225	
		L/s	3,750		3,750	
		cfm	7,945		7,945	
	Control, Driving mechanism	Inverter-control, Direct-driven by motor		Inverter-control, Direct-driven by motor		
	Motor output kW	0.92 x 1		0.92 x 1		
*3 External static press.	0 Pa (0 mmH ₂ O)		0 Pa (0 mmH ₂ O)			
Compressor	Type x Quantity	Inverter scroll hermetic compressor		Inverter scroll hermetic compressor		
	Manufacture	AC&R Works, MITSUBISHI ELECTRIC CORPORATION		AC&R Works, MITSUBISHI ELECTRIC CORPORATION		
	Starting method	Inverter		Inverter		
	Motor output kW	6.7		6.7		
	Case heater kW	0.045		0.045		
Lubricant	MEL32		MEL32			
External finish	Pre-coated galvanized steel sheets <MUNSELL 5Y 8/1 or similar>		Pre-coated galvanized steel sheets <MUNSELL 5Y 8/1 or similar>			
External dimension HxWxD	mm	1,650 x 920 x 760		1,650 x 920 x 760		
	in.	65 x 36-1/4 x 29-15/16		65 x 36-1/4 x 29-15/16		
Protection devices	High pressure protection	High pressure sensor, High pressure switch at 4.15MPa (601 psi)		High pressure sensor, High pressure switch at 4.15MPa (601 psi)		
	Inverter circuit (COMP. / FAN)	Over-heat protection, Over-current protection		Over-heat protection, Over-current protection		
	Compressor	Over-heat protection		Over-heat protection		
	Fan motor	Thermal switch		Thermal switch		
Refrigerant	Type x original charge	R410A x 9.0kg (20lbs)		R410A x 9.0kg (20lbs)		
	Control	LEV and HIC circuit				
Net weight kg(lbs)	220(486)		220(486)			
Heat exchanger	Salt-resistant cross fin & copper tube		Salt-resistant cross fin & copper tube			
HIC circuit (HIC: Heat Inter-Changer)	Copper pipe, tube-in-tube structure		Copper pipe, tube-in-tube structure			
Pipe between unit and distributor	Liquid pipe mm(in.)	9.52(3/8) Flare		9.52(3/8) Flare		
	Gas pipe mm(in.)	22.2(7/8) Brazed		22.2(7/8) Brazed		
Defrosting method	Auto-defrost mode (Reversed refrigerant circle)					
Drawing	External	WKB94R111				
	Wiring	WKE79B230		WKE79B230		
Standard attachment	Document	Installation Manual				
	Accessory	Refrigerant conn. pipe				
Optional parts	Outdoor Twinning kit: CMY-Y100VBK2 Joint: CMY-Y102S/L-G2, CMY-Y202-G2 Header: CMY-Y104/108/1010-G					
Remark	* Details on foundation work, duct work, insulation work, electrical wiring, power source switch, and other items shall be referred to the Installation Manual. * Due to continuing improvement, above specifications may be subject to change without notice.					

Note :	*1 Nominal cooling conditions (subject to JIS B8615-1)	*2 Nominal heating conditions (subject to JIS B8615-1)	Unit converter
Indoor :	27degCDB/19degCWB (81degFDB/66degFWB)	20degCDB (68degFDB)	kcal =kW x 860
Outdoor :	35degCDB (95degFDB)	7degCDB/6degCWB (45degFDB/43degFWB)	BTU/h =kW x 3,412
Pipe length :	7.5m(24-9/16ft.)	7.5m(24-9/16ft.)	cfm =m ³ /min x 35.31
Level difference :	0m(0ft.)	0m(0ft.)	lbs =kg / 0.4536
			*The specification data is subject to rounding variation.

*3 External static pressure option is available (30Pa, 60Pa / 3.1mmH₂O, 6.1mmH₂O).

PUHY-HP200, 250YHM-A(-BS)

Unit : mm

- <Accessories>
- Connecting pipe
 - Elbow (ID25.4XOD25.4)..... P200,P250 1pc.
 - Pipe (ID25.4XOD19.05)..... P200 1pc.
 - Pipe (ID25.4XOD22.2)..... P250 1pc.
 - <Liquid> · Pipe (ID9.52XOD9.52)..... P200,P250 1pc.
 - Pipe (ID9.52XOD12.7)..... P200,P250 1pc.

- Note 1. Please refer to the next page for information regarding necessary spacing around the unit and foundation work.
2. The detachable leg can be removed at site.
3. At brazing of pipes, wrap the refrigerant service valve with wet cloth and keep the temperature of refrigerant service valve under 120°C.

NO.	Usage	Specifications
①	Front through hole	102X72 Knockout hole
②	Bottom through hole	150X92 Knockout hole
③	For pipes	Front through hole ø65 or ø40 Knockout hole
④	For wires	Front through hole ø52 or ø27 Knockout hole
⑤	Bottom through hole	ø52 Knockout hole
⑥	For transmission cables	Front through hole ø34 Knockout hole

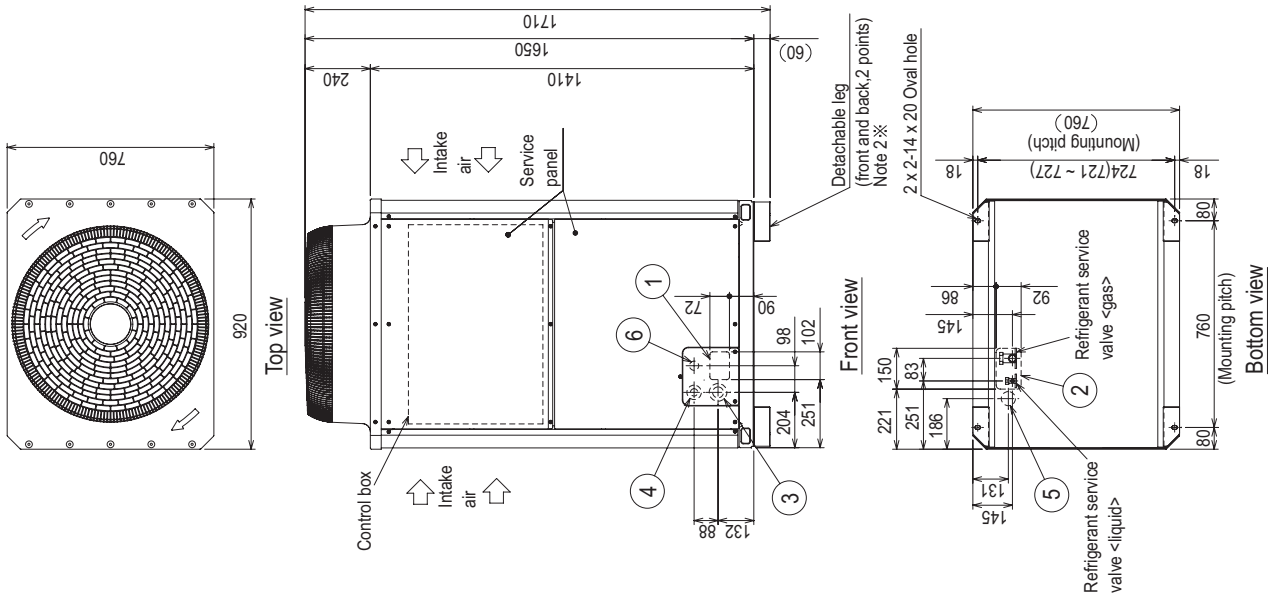

Connecting pipe specifications

Model	Position dimensions for the refrigerant service valve		Connection specifications for the refrigerant service valve *1	
	Liquid	Gas	Liquid	Gas
PUHY-HP200YHM	A	B	ø12.7 Brazed	ø19.05 Brazed
PUHY-HP250YHM	142	172	(ø9.52 Brazed) *2	ø22.2 Brazed

*1 Connect by using the connecting pipes (for bottom piping and front piping) that are supplied.

*2 Indicates dimensions and connection specifications in the case the unit is used in combination with other outdoor units.

PUHY-HP200, 250YHM-A(-BS)

Unit : mm

HP

1. Required space around the unit

● In case of single installation

- ① Secure enough space around the unit as shown in the figure below.
 - With a space of at least 300mm to the wall on the back of the unit
 - With a space of at least 100mm to the wall on the back of the unit

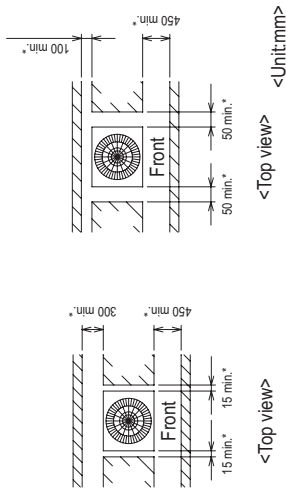

● In case of collective installation

- ① When multiple units are installed adjacent to each other, secure enough space to allow for air circulation and walkway between groups of units as shown in the figures below.
- ② At least two sides must be left open.
- ③ As with the single installation, add the height that exceeds the height limit <h> to the figures that are marked with an asterisk.

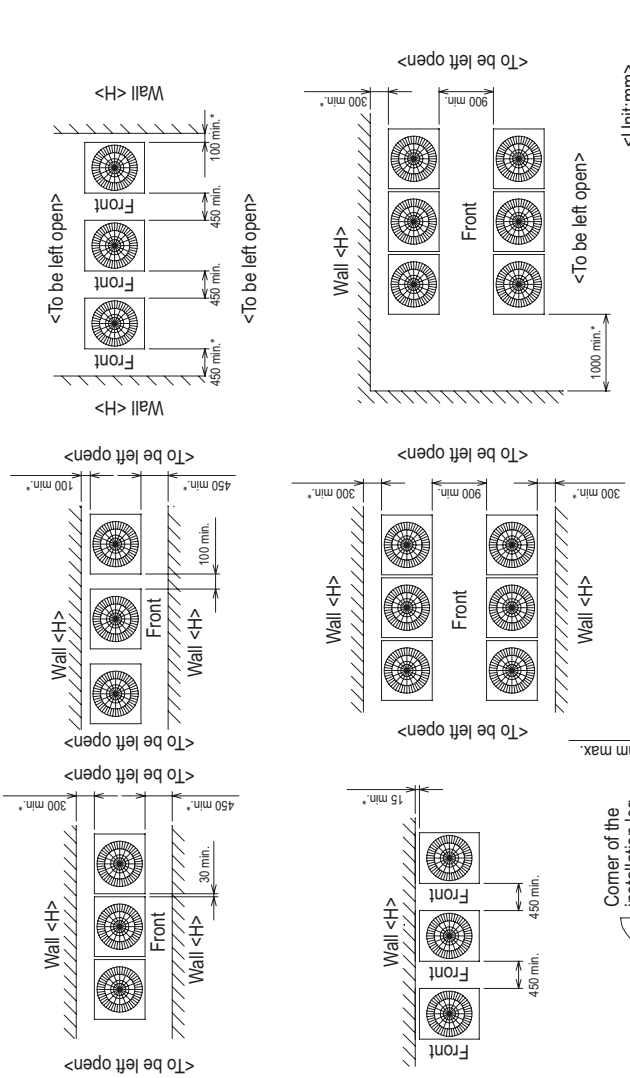

- ② When the height of the walls on the front, back or on the sides <H> exceeds the wall height limit as defined below add the height that exceeds the height limit <h> to the figures that are marked with an asterisk.

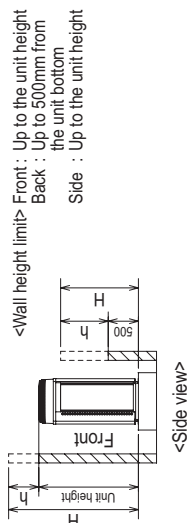

2. Foundation work

- ① Take into consideration the surface strength, water drainage route, piping route and wiring route when preparing the installation site.
 - <Note that the drain water comes out of the unit during operation.>
- ② Build the foundation in such way that the corner of the installation leg is securely supported as shown in the right figure. (Fig. A, B)
 - When using a rubber isolating cushion, please ensure it is large enough to cover the entire width of each of the unit's legs.
- ③ The protrusion length of the anchor bolt must not exceed 30mm. (Fig. A, B)
- ④ Use four fixing plates as shown in the right figure <field supply required> when using post-installed anchor bolts. (Fig. C, D)
- ⑤ To prevent small animals and water from entering the unit and damaging its parts, close the gap around the edges of through holes for pipes and wires with filler plates <field supply required>.
- ⑥ When the pipes or cables are routed at the bottom of the unit, make sure that the through hole at the base of the unit does not get blocked with the installation base.
- ⑦ Refer to the Installation Manual when installing units on an installation base.

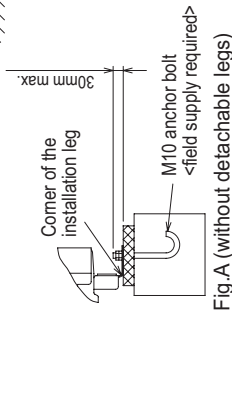

Fig.A (without detachable legs)

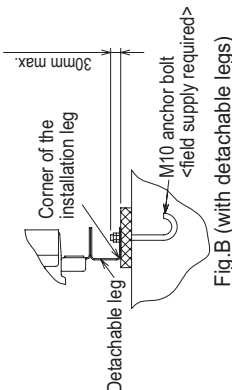

Fig.B (with detachable legs)

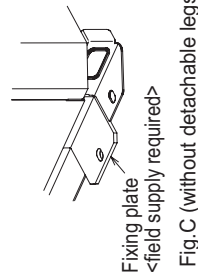

Fig.C (without detachable legs)

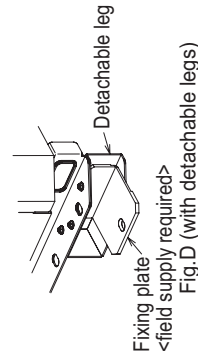
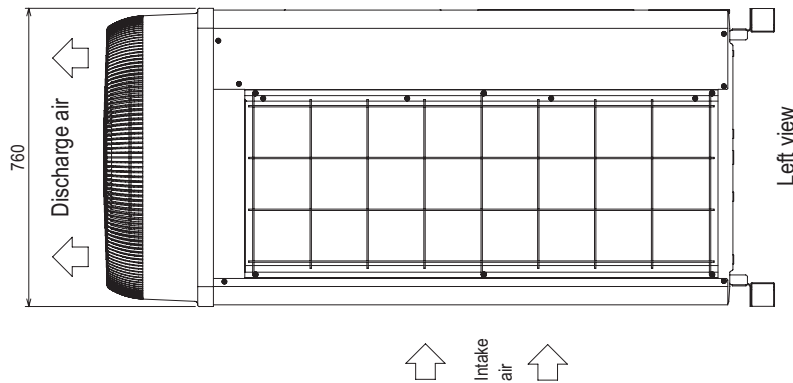
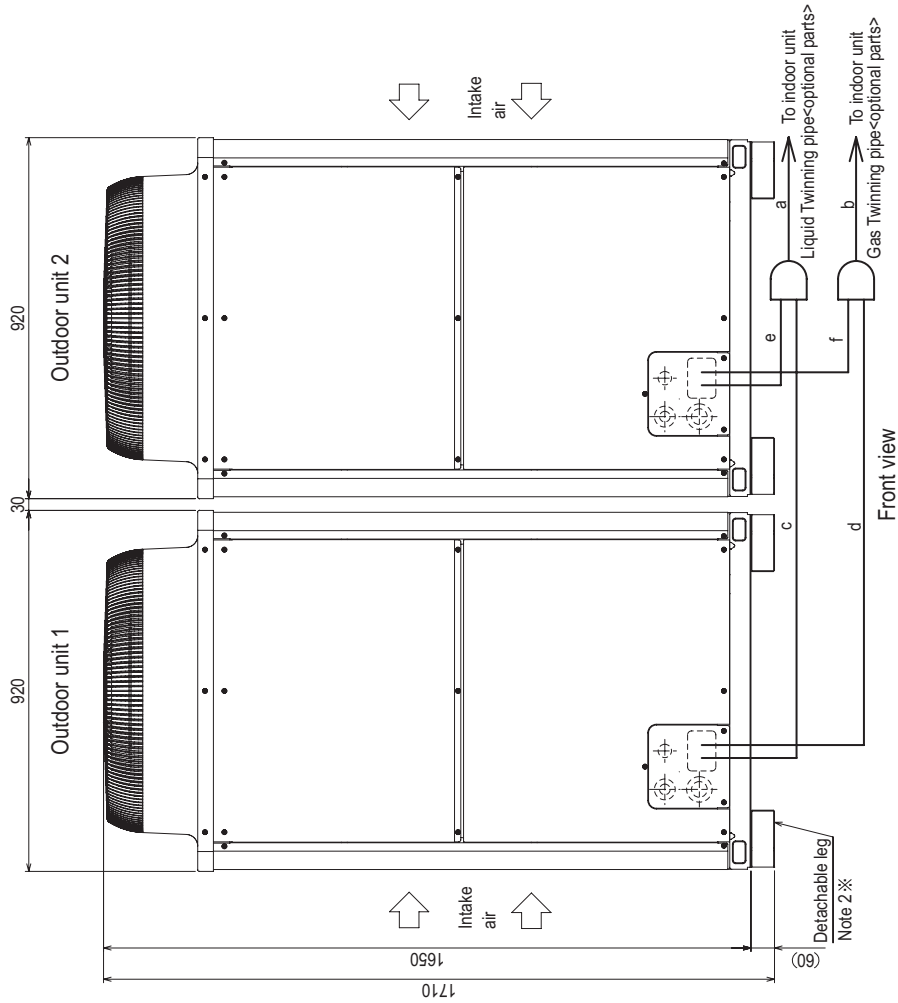

Fig.D (with detachable legs)

PUHY-HP400, 500YHM-A(-BS)

Unit : mm



- Note 1. Connect the pipes as shown in the figure above. Refer to the table above for the pipe size.
- The detachable leg can be removed at site.
 - Twinning pipes should not be tilted more than 15 degrees from the ground. Be sure to see the Installation Manual for details of Twinning pipe installation.
 - The pipe section before the Twinning pipe (sections "a" and "b" in the figure) must have at least 500mm of straight section (*including the straight pipe that is supplied with the Twinning pipe).
 - Only use the Twinning pipe by Mitsubishi (optional parts).

Twinning pipe connection size

Package unit name	PUHY-HP400YSHM-A(-BS)	PUHY-HP500YSHM-A(-BS)
Outdoor unit 1	PUHY-HP200YHM-A(-BS)	PUHY-HP250YHM-A(-BS)
Outdoor unit 2	PUHY-HP200YHM-A(-BS)	PUHY-HP250YHM-A(-BS)
Outdoor Twinning Kit(optional parts)	CMY-Y100YBK2	
Indoor unit-Twinning pipe	Liquid a	ø15.88
	Gas b	ø28.58
Twinning pipe-Outdoor unit 1	Liquid c	ø9.52
	Gas d	ø19.05
Twinning pipe-Outdoor unit 2	Liquid e	ø9.52
	Gas f	ø19.05

PUHY-HP200,250YHM-A

Unit : mm(in.)

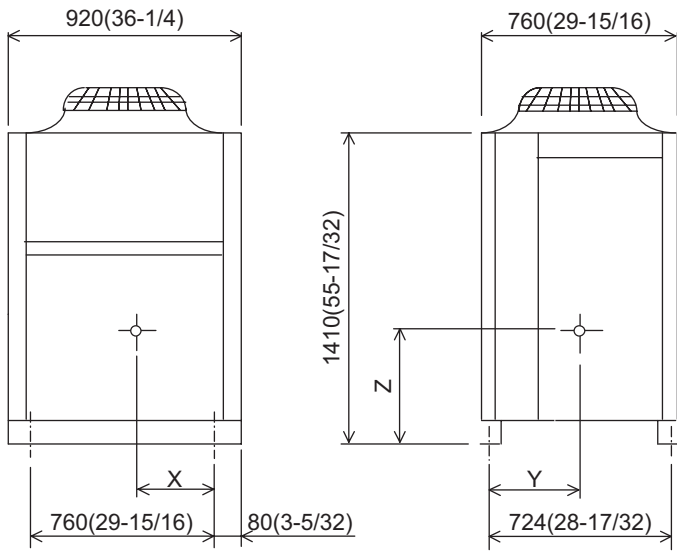

Model	X	Y	Z
PUHY-HP200YHM-A	315(12-13/32)	317(12-1/2)	635(25)
PUHY-HP250YHM-A	315(12-13/32)	317(12-1/2)	635(25)

HP

PUHY-HP200, 250YHM-A(-BS)

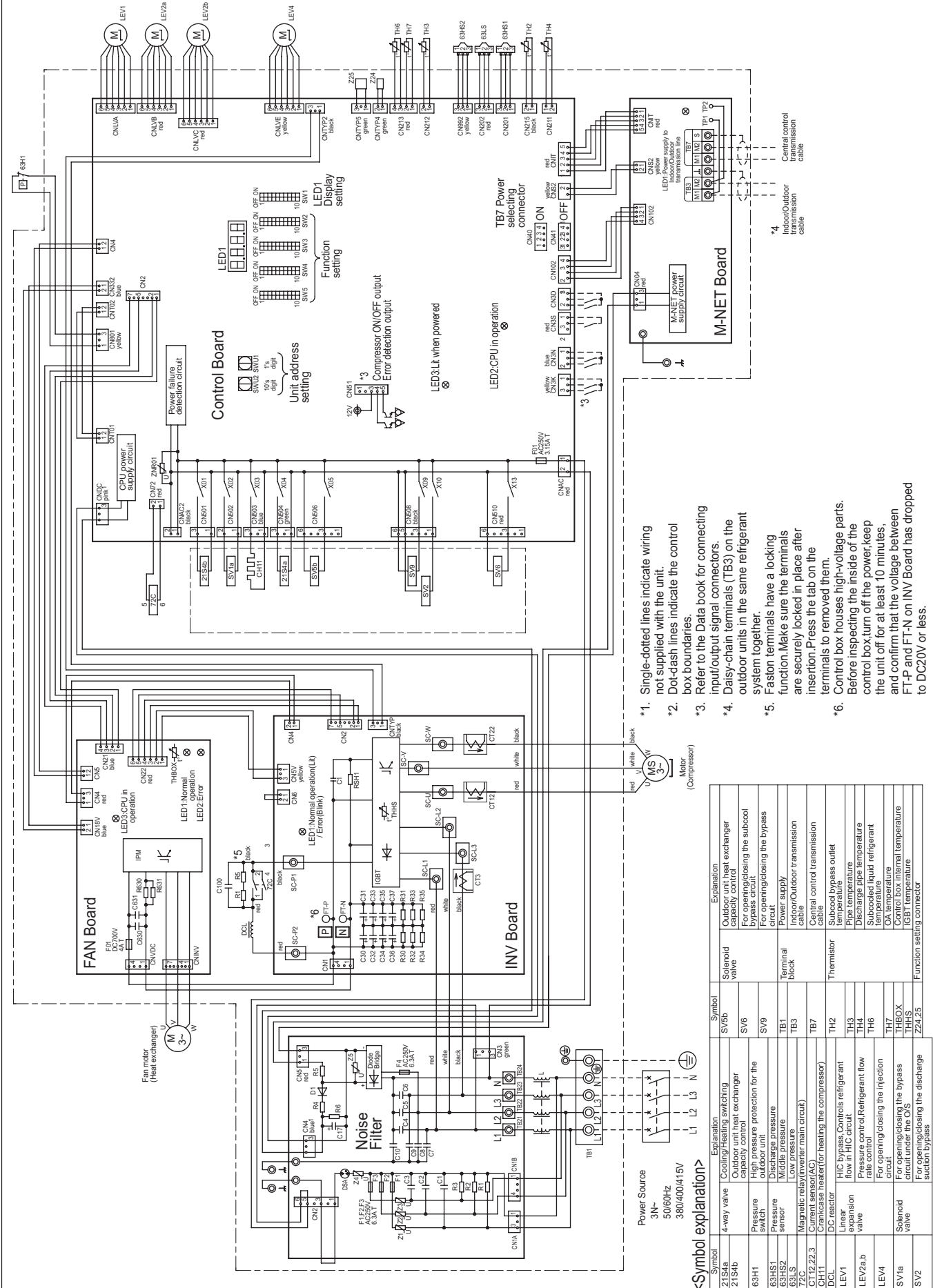

- *1. Single-dotted lines indicate wiring not supplied with the unit.
- *2. Dot-dash lines indicate the control box boundaries.
- *3. Refer to the Data book for connecting input/output signal connectors.
- *4. Daisy-chain terminals (TB3) on the outdoor units in the same refrigerant system together.
- *5. Faston terminals have a locking function. Make sure the terminals are securely locked in place after insertion. Press the tab on the terminals to removed them.
- *6. Control box houses high-voltage parts. Before inspecting the inside of the control box, turn off the power, keep the unit off for at least 10 minutes, and confirm that the voltage between FT-P and FT-N on INV Board has dropped to DC20V or less.

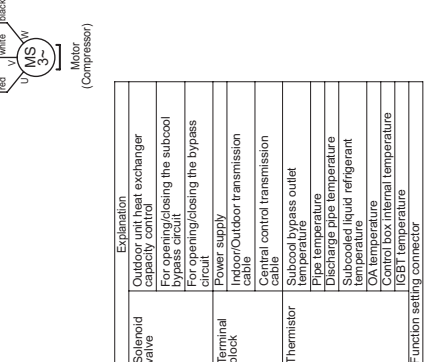

<Symbol explanation>

Symbol	Explanation	Symbol	Explanation
2-1S4b	Coil switching capacity control	SV5b	Solenoid valve
63H1	High pressure protection for the outdoor unit	SV6	Subcooling capacity control
63HS1	Discharge pressure	SV9	For opening/closing the subcool bypass circuit
63LS	Middle pressure	TB1	Power supply
63LS	Low pressure	TB3	Inoor/Outdoor transmission cable
Z1-Z2-Z3	Magnetic relay (for main circuit)	TB7	Subcool control transmission cable
CH11	Crankcase heater (for heating the compressor)	TH2	Thermistor
DCL	DC reactor	TH3	Subcool bypass outlet temperature
LEV1	HIC bypass. Controls refrigerant flow in HIC circuit	TH4	Pipe temperature
LEV2a/b	Pressure control/Refrigerant flow rate control	TH6	Subcooled liquid refrigerant temperature
LEV4	For opening/closing the injection	TH7	Oil temperature
SV1a	For opening/closing the bypass circuit under the O/S	THHS	Control box internal temperature
SV2	For opening/closing the discharge suction bypass	Z24-Z5	Function setting connector

Measurement condition
PUHY-HP200,250YHM-A

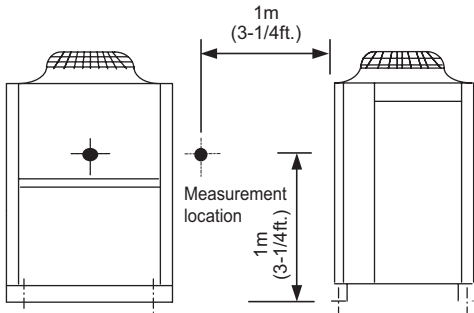

Measurement condition
PUHY-HP400,500YSHM-A

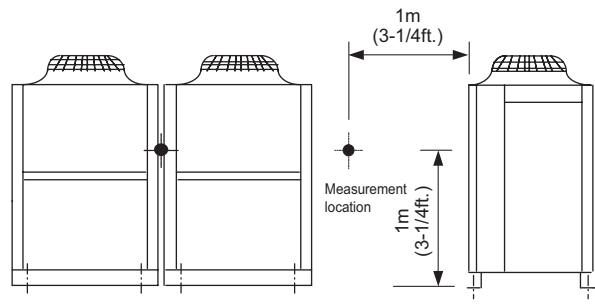

Sound level of PUHY-HP200YHM-A(-BS)

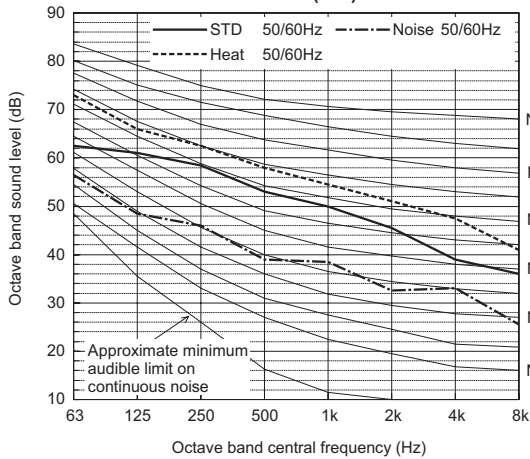

	63	125	250	500	1k	2k	4k	8k	dB(A)
STD cool/heat 50/60Hz	62.5	61.0	58.5	53.0	50.0	45.5	39.0	36.0	56.0
Low temp. heating 50/60Hz	73.0	66.0	62.5	58.0	54.5	51.0	47.5	41.0	61.0
Low noise mode 50/60Hz	56.5	48.5	46.0	39.0	38.5	32.5	33.0	25.5	44.0

When Low noise mode is set, the A/C system's capacity is limited. The system could return to normal operation from Low noise mode automatically in the case that the operation condition is severe.

Sound level of PUHY-HP400YSHM-A(-BS)

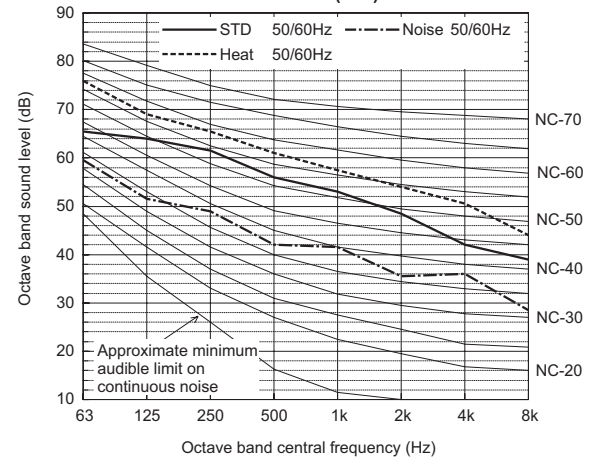

	63	125	250	500	1k	2k	4k	8k	dB(A)
STD cool/heat 50/60Hz	65.5	64.0	61.5	56.0	53.0	48.5	42.0	39.0	59.0
Low temp. heating 50/60Hz	76.0	69.0	65.5	61.0	57.5	54.0	50.5	44.0	64.0
Low noise mode 50/60Hz	59.5	51.5	49.0	42.0	41.5	35.5	36.0	28.5	47.0

When Low noise mode is set, the A/C system's capacity is limited. The system could return to normal operation from Low noise mode automatically in the case that the operation condition is severe.

Sound level of PUHY-HP250YHM-A(-BS)

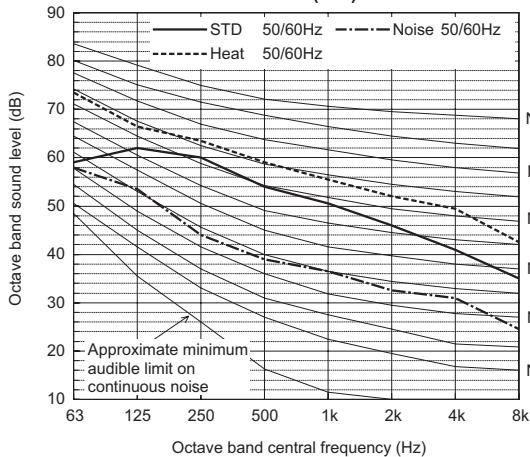

	63	125	250	500	1k	2k	4k	8k	dB(A)
STD cool/heat 50/60Hz	59.0	62.0	60.0	54.0	50.5	46.0	41.0	35.0	57.0
Low temp. heating 50/60Hz	73.5	66.5	63.5	59.0	55.5	52.0	49.5	42.5	62.0
Low noise mode 50/60Hz	58.0	53.5	44.0	39.0	36.5	32.5	31.0	24.5	44.0

When Low noise mode is set, the A/C system's capacity is limited. The system could return to normal operation from Low noise mode automatically in the case that the operation condition is severe.

Sound level of PUHY-HP500YSHM-A(-BS)

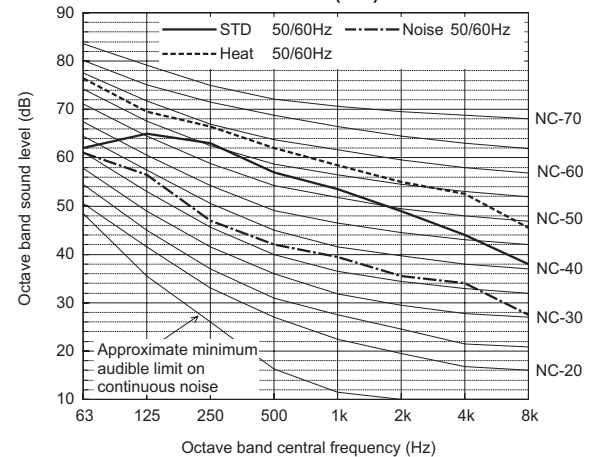

	63	125	250	500	1k	2k	4k	8k	dB(A)
STD cool/heat 50/60Hz	62.0	65.0	63.0	57.0	53.5	49.0	44.0	38.0	60.0
Low temp. heating 50/60Hz	76.5	69.5	66.5	62.0	58.5	55.0	52.5	45.5	65.0
Low noise mode 50/60Hz	61.0	56.5	47.0	42.0	39.5	35.5	34.0	27.5	47.0

When Low noise mode is set, the A/C system's capacity is limited. The system could return to normal operation from Low noise mode automatically in the case that the operation condition is severe.

6-1. Correction by temperature

CITY MULTI could have varied capacity at different designing temperature. Using the nominal cooling/heating capacity value and the ratio below, the capacity can be observed at various temperature.

PUHY-		HP200YHM	HP250YHM
Nominal Cooling Capacity	kW	22.4	28.0
	BTU/h	76,400	95,500
Input	kW	6.40	9.06

PUHY-		HP400YSHM	HP500YSHM
Nominal Cooling Capacity	kW	45.0	56.0
	BTU/h	153,500	191,100
Input	kW	12.86	18.16

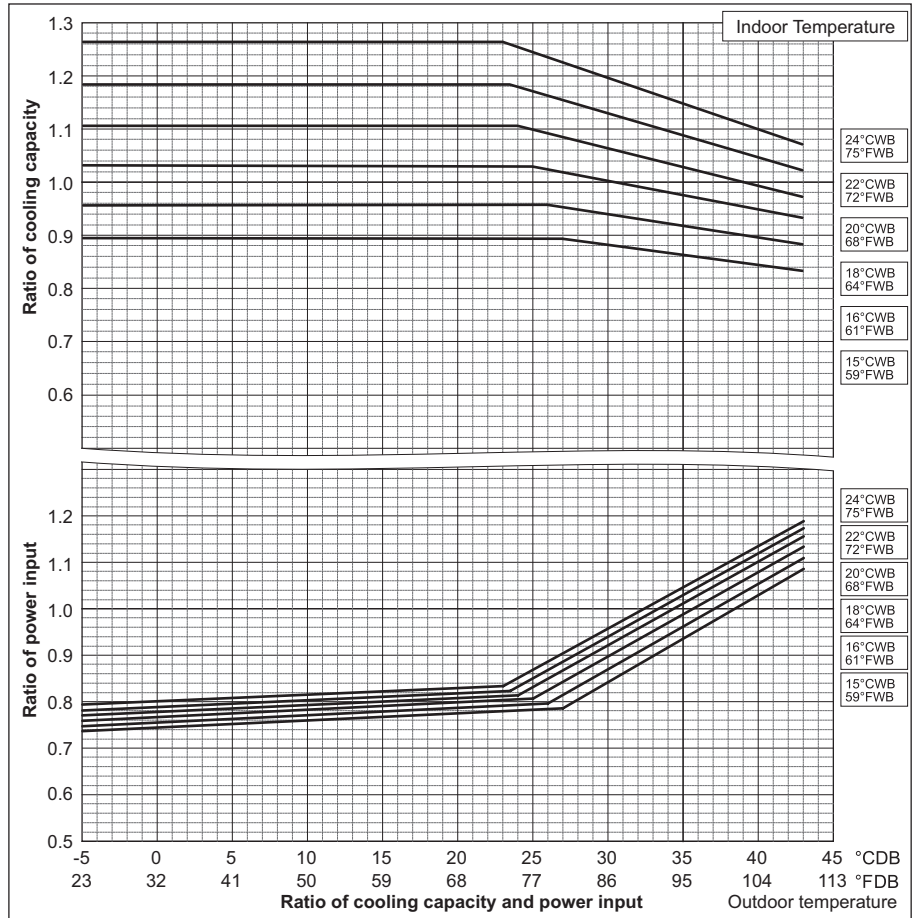

PUHY-		HP200YHM	HP250YHM
Nominal Heating Capacity	kW	25.0	31.5
	BTU/h	85,300	107,500
Input	kW	6.52	8.94

PUHY-		HP400YSHM	HP500YSHM
Nominal Heating Capacity	kW	50.0	63.0
	BTU/h	170,600	215,000
Input	kW	13.35	18.04

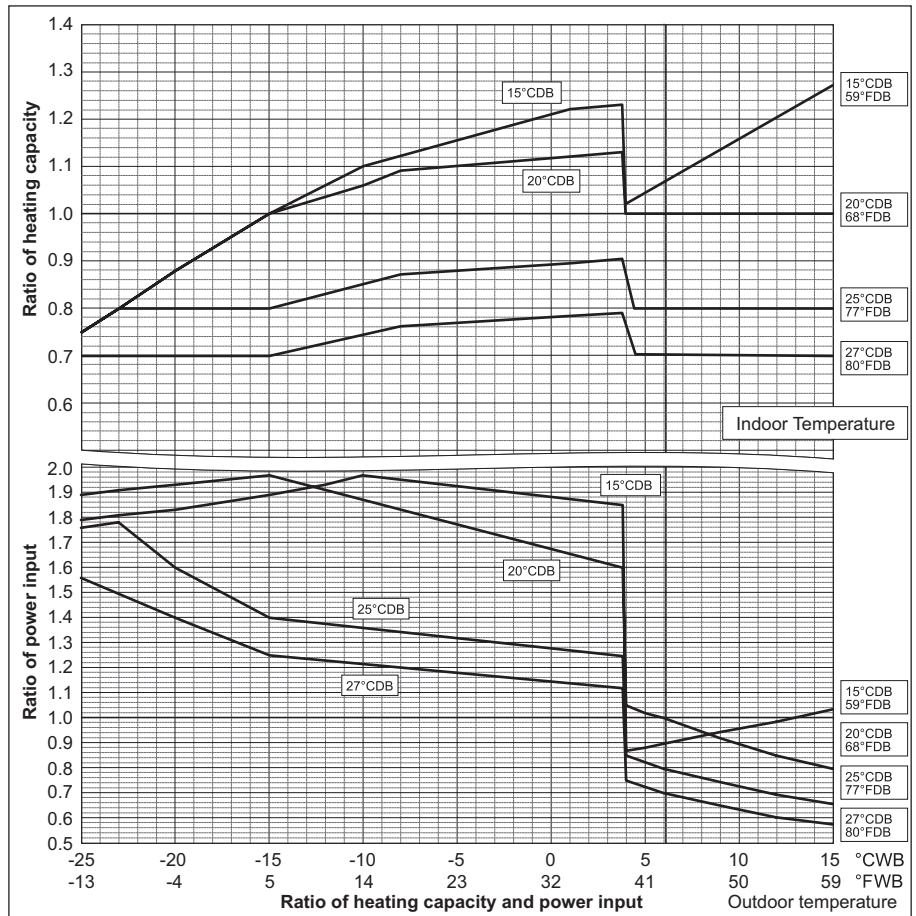

6-2. Correction by total indoor

CITY MULTI system has different capacity and input at different total capacity of indoor unit connected. Using following tables, the maximum capacity can be observed so as to ensure the system having enough capacity.

HP

PUHY-HP200YHM-A

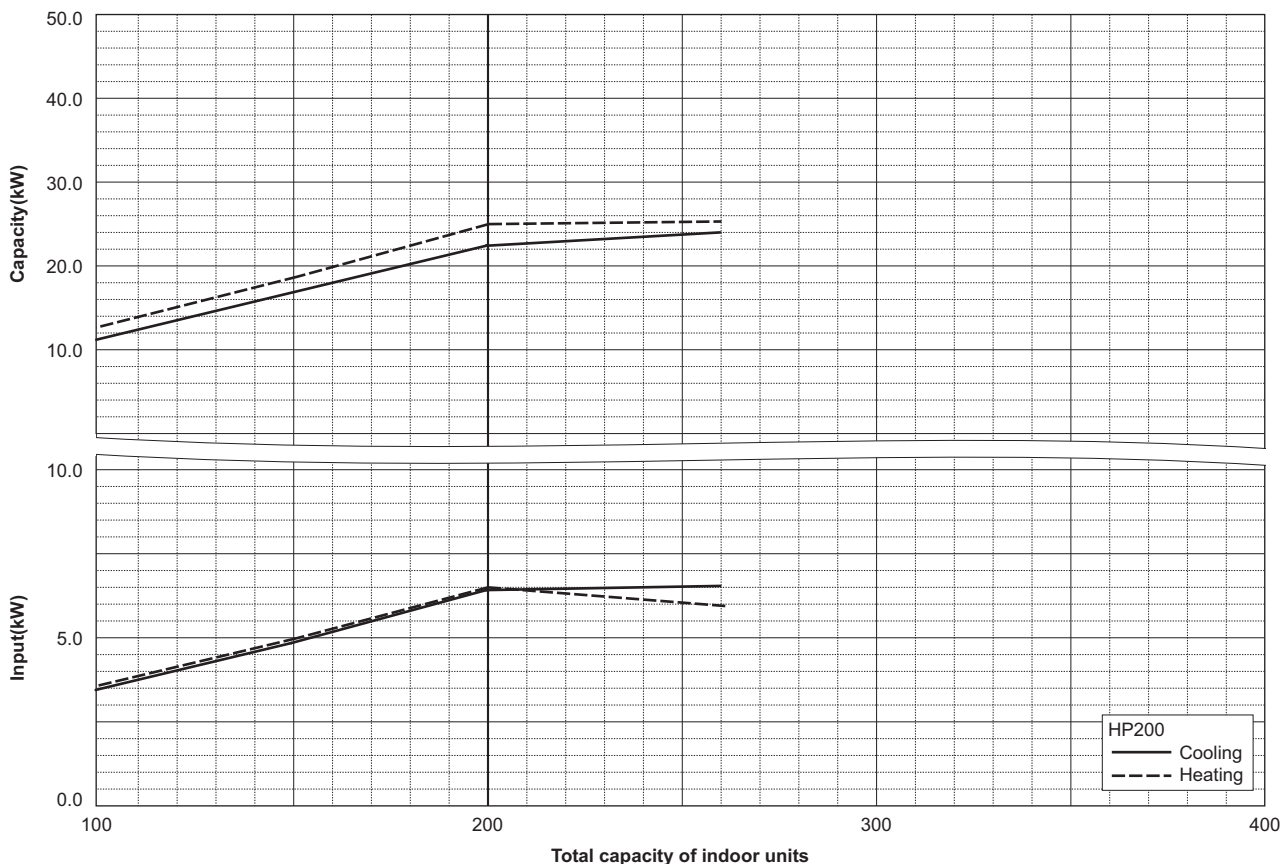

PUHY-HP250YHM-A

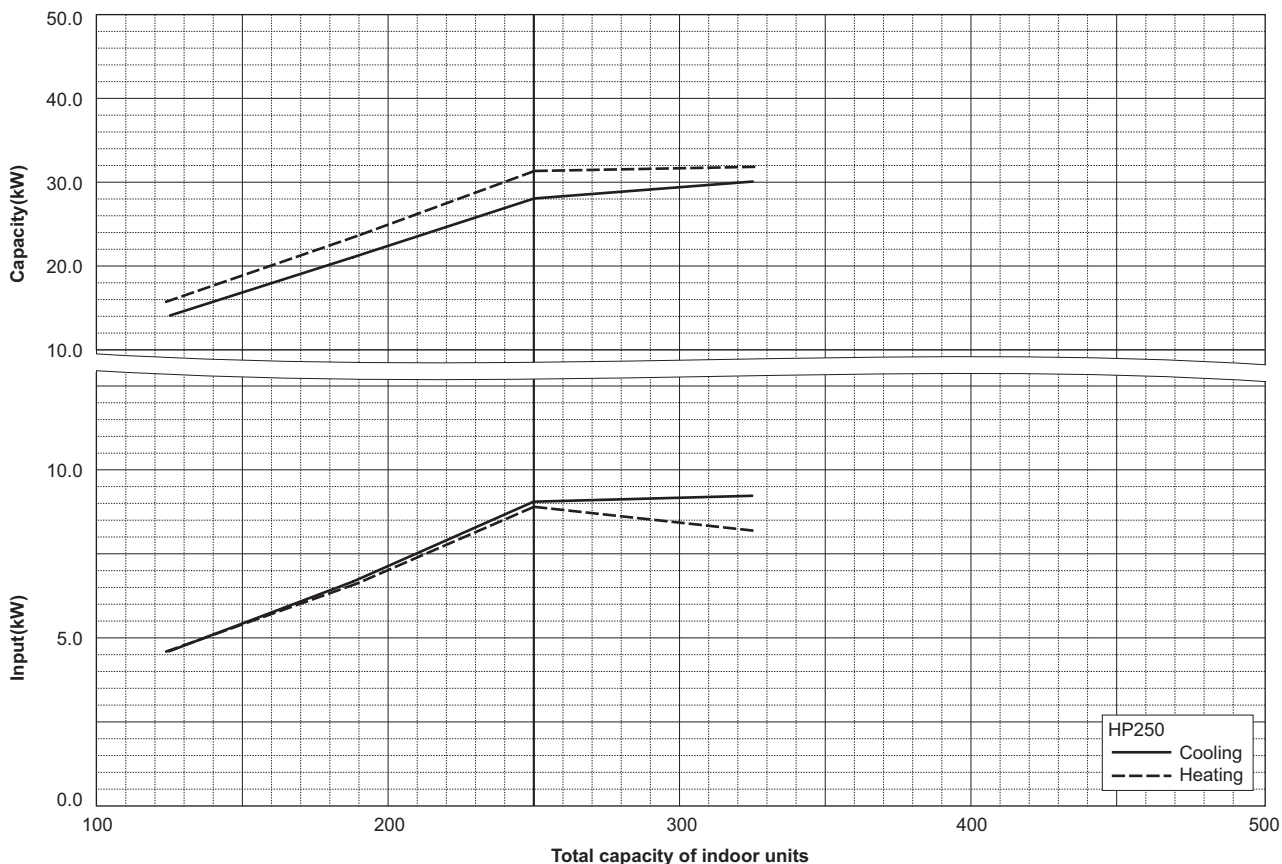

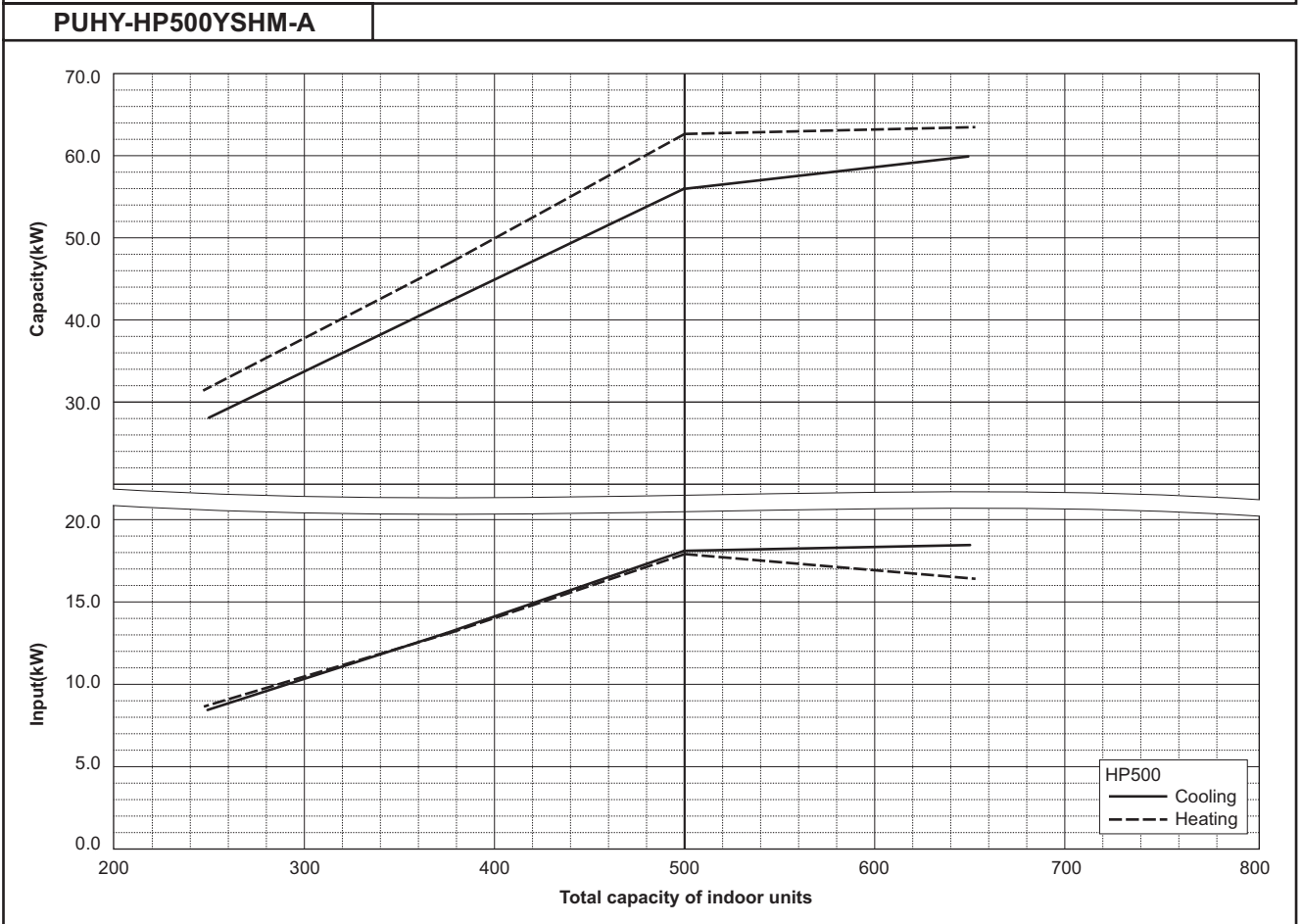
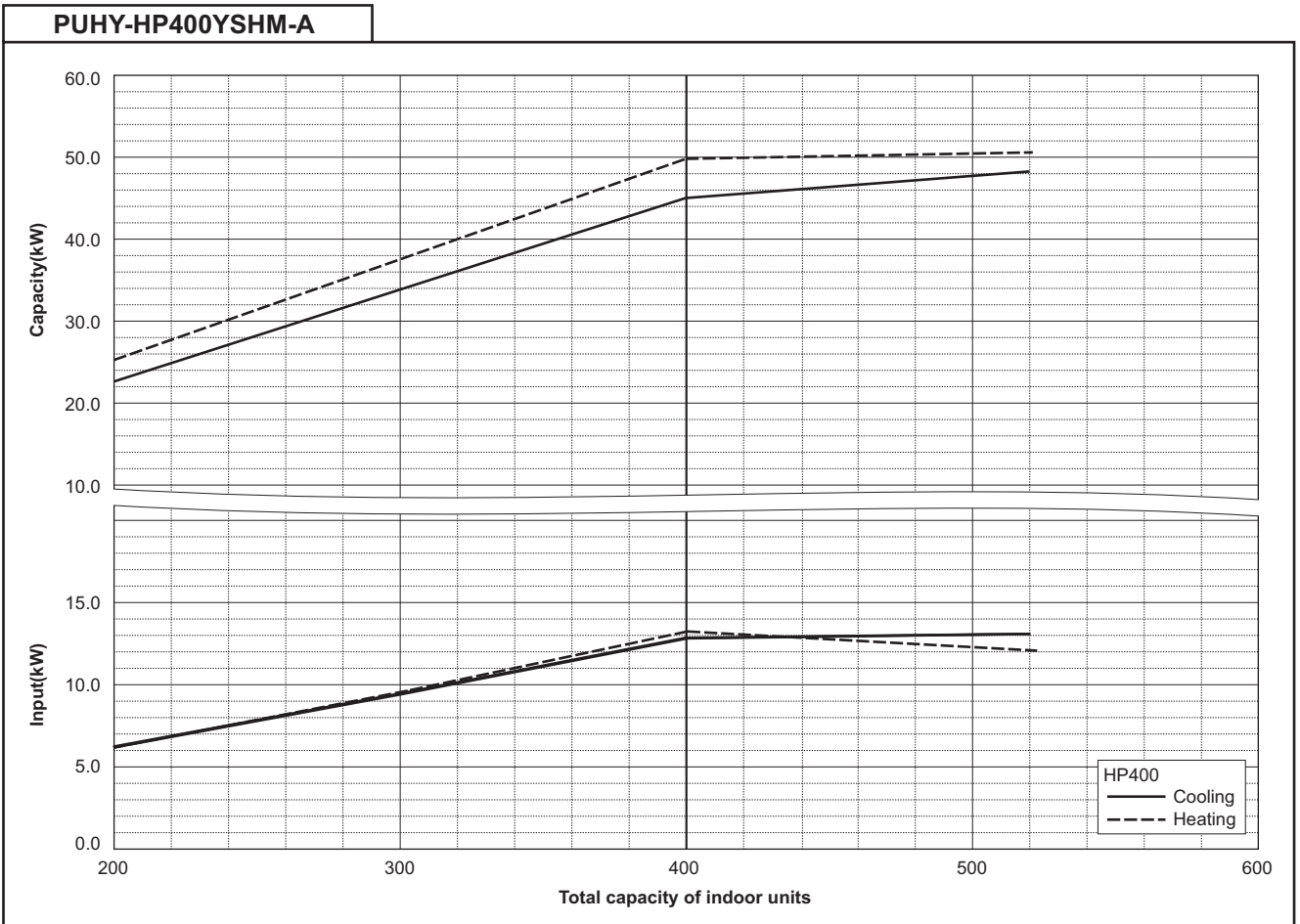

6-3. Correction by refrigerant piping length

CITY MULTI system can extend the piping flexibly within its limitation for the actual situation. Yet, a decrease of cooling/heating capacity could happen correspondently. Using following correction factor according to the equivalent length of the piping shown at 6-3-1 and 6-3-2, the capacity can be observed. 6-3-3 shows how to obtain the equivalent length of piping.

6-3-1. Cooling capacity correction

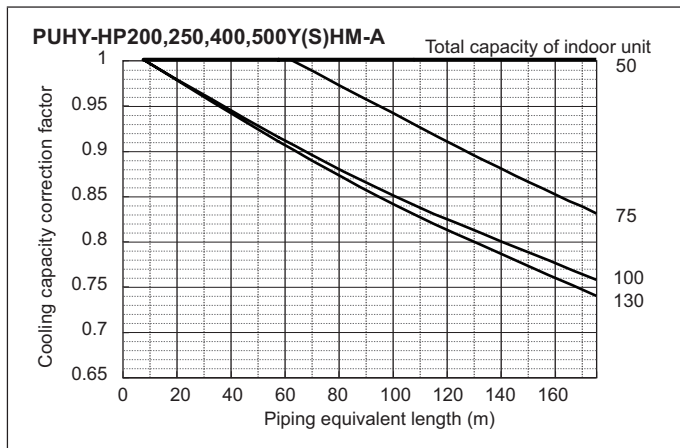

6-3-2. Heating capacity correction

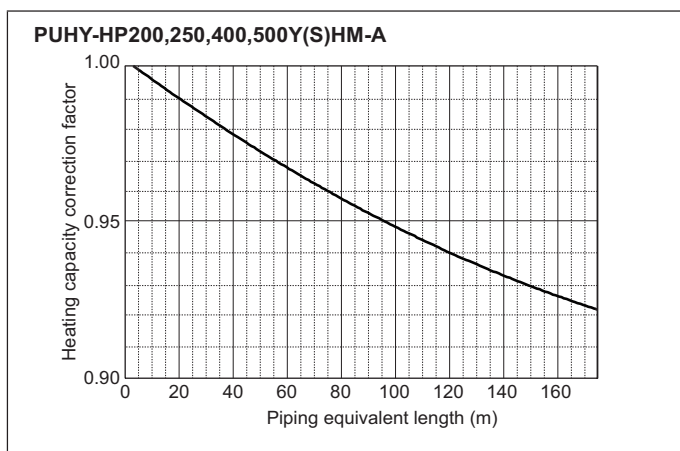

6-3-3. How to obtain the equivalent piping length

- 1 **PUHY-HP200YHM**
Equivalent length = (Actual piping length to the farthest indoor unit) + (0.35 x number of bends in the piping) m
- 2 **PUHY-HP250YHM**
Equivalent length = (Actual piping length to the farthest indoor unit) + (0.42 x number of bends in the piping) m
- 3 **PUHY-HP400,500YSHM**
Equivalent length = (Actual piping length to the farthest indoor unit) + (0.50 x number of bends in the piping) m

6-4. Correction at frost and defrost

Due to frost at the outdoor heat exchanger and the automatic defrost operation, the heating capacity of the outdoor unit can be calculated by multiplying the correction factor shown in the table below.

Table of correction factor at frost and defrost

Outdoor inlet air temp. °CWB	6	4	2	1	0	-2	-4	-6	-8	-10	-25
Outdoor inlet air temp. °FWB	43	39	36	34	32	28	25	21	18	14	-13
PUHY-HP200,250,400,500Y(S)HM	1.00	0.95	0.85	0.85	0.85	0.87	0.87	0.87	0.87	0.92	0.95

6-5. Operation temperature range

• Cooling

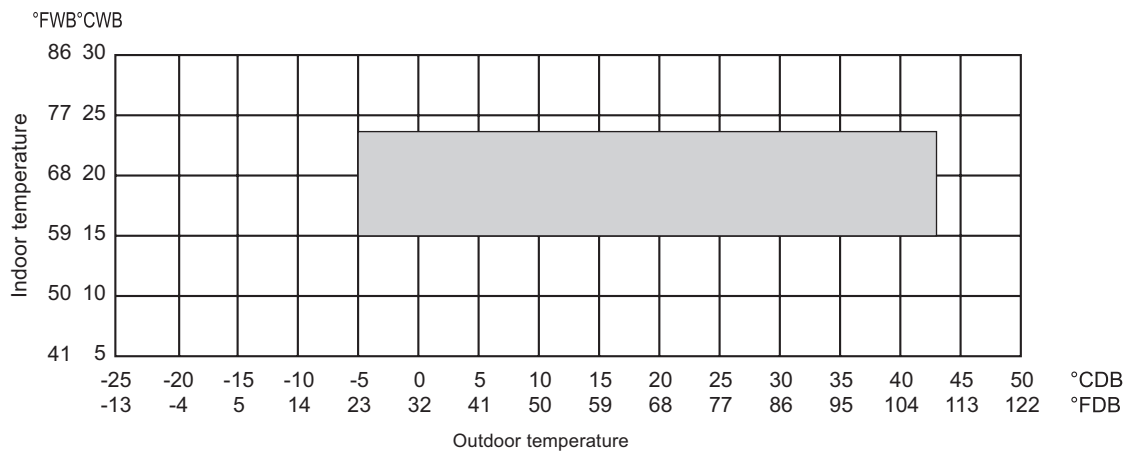

• Heating

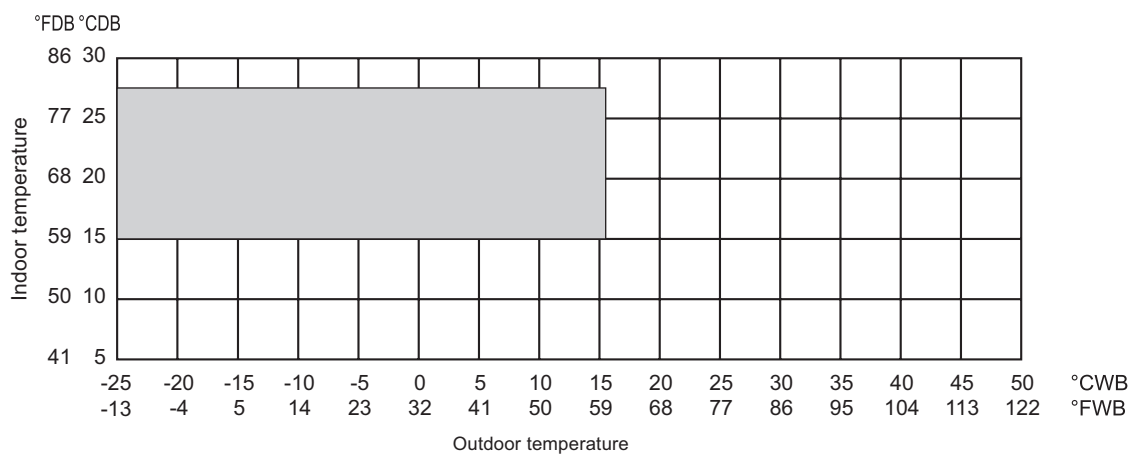

HP

7-1. JOINT

Piping for CITY MULTI can be easily done with Joints and headers provided by MITSUBISHI ELECTRIC CORP. There are 4 sets of Joints selectable for piping. Details for applying the Joint sets are referable to System Design 3, or their own Installation Manual.

CMY-Y102S-G2

Ref.: CMY_Y102S_G2_EXD_EUDB_SI
mm

For Gas pipe:

For Liquid pipe:

<Deformed pipe(Accessory)>

<Deformed pipe(Accessory)>

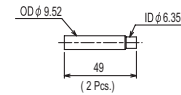
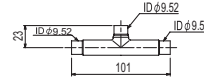
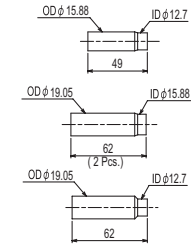
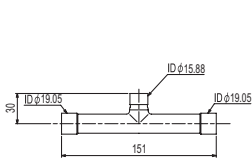

ID: Inner Diameter OD: Outer Diameter

CMY-Y102L-G2

Ref.: CMY_Y102L_G2_EXD_EUDB_SI
mm

For Gas pipe:

For Liquid pipe:

<Deformed pipe(Accessory)>

<Deformed pipe(Accessory)>

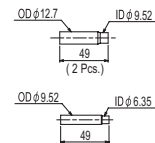
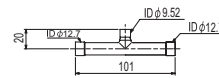
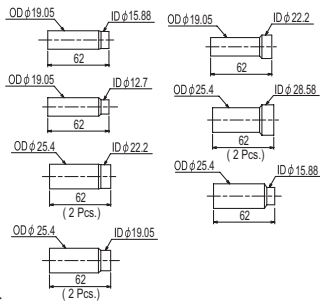
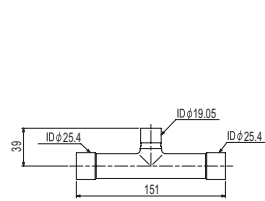

ID: Inner Diameter OD: Outer Diameter

CMY-Y202-G2

Ref.: CMY_Y202_G2_EXD_EUDB_SI
mm

For Gas pipe:

For Liquid pipe:

<Deformed pipe(Accessory)>

<Deformed pipe(Accessory)>

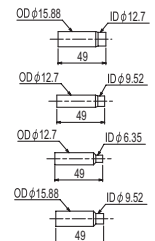
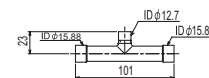
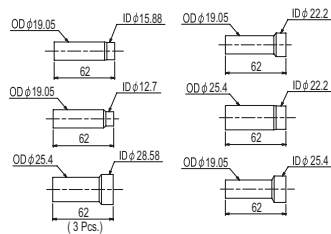
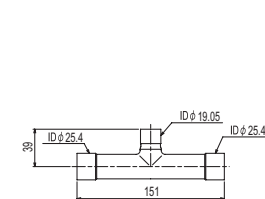

ID: Inner Diameter OD: Outer Diameter

7-2. HEADER

Piping for CITY MULTI can be easily done with Joints and Headers provided by MITSUBISHI ELECTRIC CORP. There are 3 sets of Headers selectable for piping. Details for applying the Header sets are referable to System Design 3, or their own Installation Manual.

CMY-Y104-G Ref.: CMY_Y104-G_EXD_EUDB_SI mm

For Gas pipe:

<Deformed pipe(Accessory)>

For Liquid pipe:

<Deformed pipe(Accessory)>

ID: Inner Diameter OD: Outer Diameter
NOTE: Besides above mentioned accessories, caps for pipe of φ 6.35, φ 9.52, φ 12.7, φ 15.88 (each diameter 1 piece) are included in the Header set.

CMY-Y108-G Ref.: CMY_Y108-G_EXD_EUDB_SI mm

For Gas pipe:

<Deformed pipe(Accessory)>

For Liquid pipe:

<Deformed pipe(Accessory)>

ID: Inner Diameter OD: Outer Diameter
NOTE: Besides above mentioned accessories, caps for pipe of φ 6.35, φ 9.52, φ 12.7, φ 15.88 (each diameter 2 pieces) and 1 cap for pipe of φ 19.05 are included in the Header set.

CMY-Y1010-G Ref.: CMY_Y1010-G_EXD_EUDB_SI mm

For Gas pipe:

<Deformed pipe(Accessory)>

For Liquid pipe:

<Deformed pipe(Accessory)>

ID: Inner Diameter OD: Outer Diameter
NOTE: Besides above mentioned accessories, caps for pipe of φ 6.35, φ 9.52, φ 12.7, φ 15.88 (each diameter 2 pieces) and 1 cap for pipe of φ 19.05 are included in the Header set.

7-3. OUTDOOR TWINNING KIT

For PUHY-HP-YSHM, following optional Outdoor Twinning Kit is needed to use to combine to refrigerant flows of its PUHY-HP-YHM. Details of selecting the proper kit should be referred to the System Design Section.

CMY-Y100VBK2

mm

For Gas pipe:

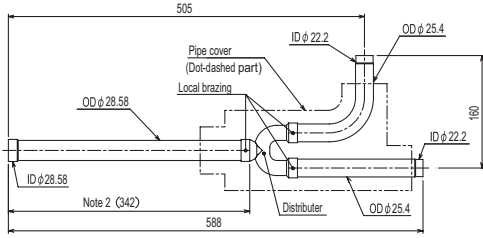

For Liquid pipe:

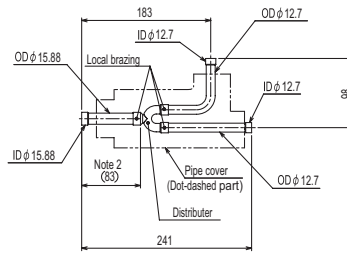

<Deformed pipe(Accessory)>

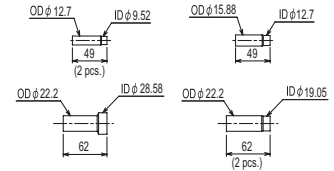

ID: Inner Diameter OD: Outer Diameter

Note 1. Reference the attitude angle of the branch pipe below the fig.

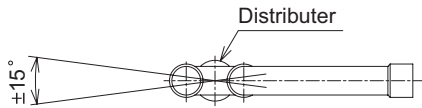

The angle of the branch pipe is within $\pm 15^\circ$ against the horizontal plane.

2. Use the attached pipe to braze the port-opening of the distributor.
3. Pipe diameter is indicated by inside diameter.